

[128392]

DE 9-11-15  
C'LESS TG/DE 9-5-18  
PLUNGE ON DEDTRU  
NO BACKTAPER  
PLUNGE FIRST STEP TO .298  
PLUNGE SECOND STEP TO .270

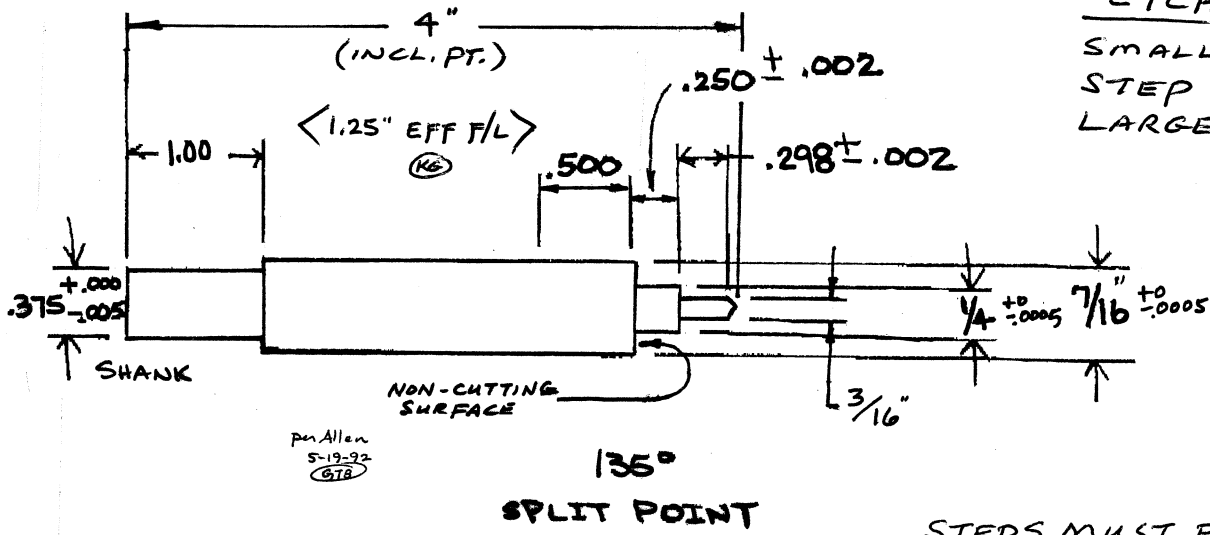

ETCH  
SMALL DIA  
STEP DIA  
LARGE DIA

STEPS MUST BE FINISHED  
IN MACHINE GRIND BEFORE  
FLUTING

3-30-09

KG 5-12-92

MACHINE GRIND

FLUTING

LEAVE FIRST STEP  
.005 OVER FOR ANCA  
GRIND SECOND STEP  
TO LENGTH

5/16" P/F WHEEL  
HEAD AT 27°  
WEB .055-.060 Front  
.135-.140 Back  
FEEDRATE 5.0  
OVERRIDE 30%  
NO O.D. BACKOFF  
1.25" F/L (+WASHOUT)

ANCA 11-10-95  
135° DRILL POINT  
THIN WEB  
RELIEVE 3/16" & 1/4"  
STEP DIAS.

600X DRILLS TG 9-5-18  
FLUTE WHEEL RADIUS .166  
O.D. WHEEL 3/8"

HAND GRIND

SPLIT AND RELIEVE  
FIRST BACKANGLE

(RAW: GCI 7/16 x 4) TP 8-31-16

STEP DRILL  
SOLID CARBIDE-MICROGRAIN  
2 RHS FLUTES  
25° HELIX

DCT IND'L.