

SK (1/4" Steel Shank)
SL (1/4" Steel Shank)

Carbide Rotary Files - Taper Shape (90° Included Angle)

Submicron Grain Carbide

D - Double Cut

** - Solid Carbide/Double End

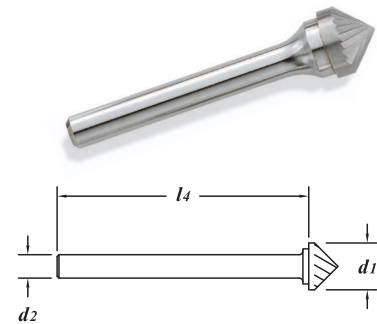

EDP#	TOOL #	$d1$ † Diameter		$d2$ Shank Diameter	$l4$ Shank Length		
		Decimal	Metric				
**	68010	SK-1	.2500	1/4"	6.350	1/4"	1-11/16"
**	68012	SK-1D	.2500	1/4"	6.350	1/4"	1-11/16"
	68020	SK-3	.3750	3/8"	9.525	1/4"	1-3/4"
	68022	SK-3D	.3750	3/8"	9.525	1/4"	1-3/4"
	68030	SK-5	.5000	1/2"	12.700	1/4"	1-3/4"
	68032	SK-5D	.5000	1/2"	12.700	1/4"	1-3/4"
	68040	SK-6	.6250	5/8"	15.875	1/4"	1-3/4"
	68042	SK-6D	.6250	5/8"	15.875	1/4"	1-3/4"
	68050	SK-7	.7500	3/4"	19.050	1/4"	1-3/4"
	68052	SK-7D	.7500	3/4"	19.050	1/4"	1-3/4"
	68070	SK-9	1.000	1"	25.400	1/4"	1-3/4"
	68072	SK-9D	1.000	1"	25.400	1/4"	1-3/4"

Carbide Rotary Files - Cone-Radius Shape (14° Included Angle)

Submicron Grain Carbide

A - Aluminum Cut

D - Double Cut

* - Solid Carbide

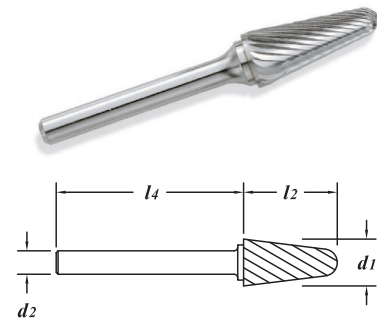

EDP#	TOOL #	$d1$ † Diameter		$d2$ Shank Diameter	$l2$ Flute Length	$l4$ Shank Length		
		Decimal	Metric					
*	69010	SL-1	.2500	1/4"	6.350	1/4"	5/8"	2"
*	69012	SL-1D	.2500	1/4"	6.350	1/4"	5/8"	2"
	69020	SL-2	.3125	5/16"	7.938	1/4"	7/8"	1-3/4"
	69022	SL-2D	.3125	5/16"	7.938	1/4"	7/8"	1-3/4"
	69030	SL-3	.3750	3/8"	9.525	1/4"	1-1/16"	1-3/4"
	69031	SL-3A	.3750	3/8"	9.525	1/4"	1-1/16"	1-3/4"
	69032	SL-3D	.3750	3/8"	9.525	1/4"	1-1/16"	1-3/4"
	69040	SL-4	.5000	1/2"	12.700	1/4"	1-1/8"	1-3/4"
	69041	SL-4A	.5000	1/2"	12.700	1/4"	1-1/8"	1-3/4"
	69042	SL-4D	.5000	1/2"	12.700	1/4"	1-1/8"	1-3/4"
	69050	SL-5	.6250	5/8"	15.875	1/4"	1-3/16"	1-3/4"
	69051	SL-5A	.6250	5/8"	15.875	1/4"	1-3/16"	1-3/4"
	69052	SL-5D	.6250	5/8"	15.875	1/4"	1-3/16"	1-3/4"
	69060	SL-7	.7500	3/4"	19.050	1/4"	1-1/2"	1-3/4"
	69062	SL-7D	.7500	3/4"	19.050	1/4"	1-1/2"	1-3/4"